

Designed and built by Peer Frank

span: 23.2 m
 wing area: 16.9 m²
 aspect ratio: 32
 empty weight: 30.5 kg
 design speed: 8.6 m/s
 design power: 225 W (pilot: 85kg = 85% of pilots aerobic power)
 wing airfoil: PF25
 stabiliser airfoil: Eppler 182
 rudder airfoil: PF9
 prop airfoil: FX 60-100
 prop diameter: 2.80 m
 prop speed: 190 rpm

WING RIB
 Airfoil: PF25
 Scale: 1:4

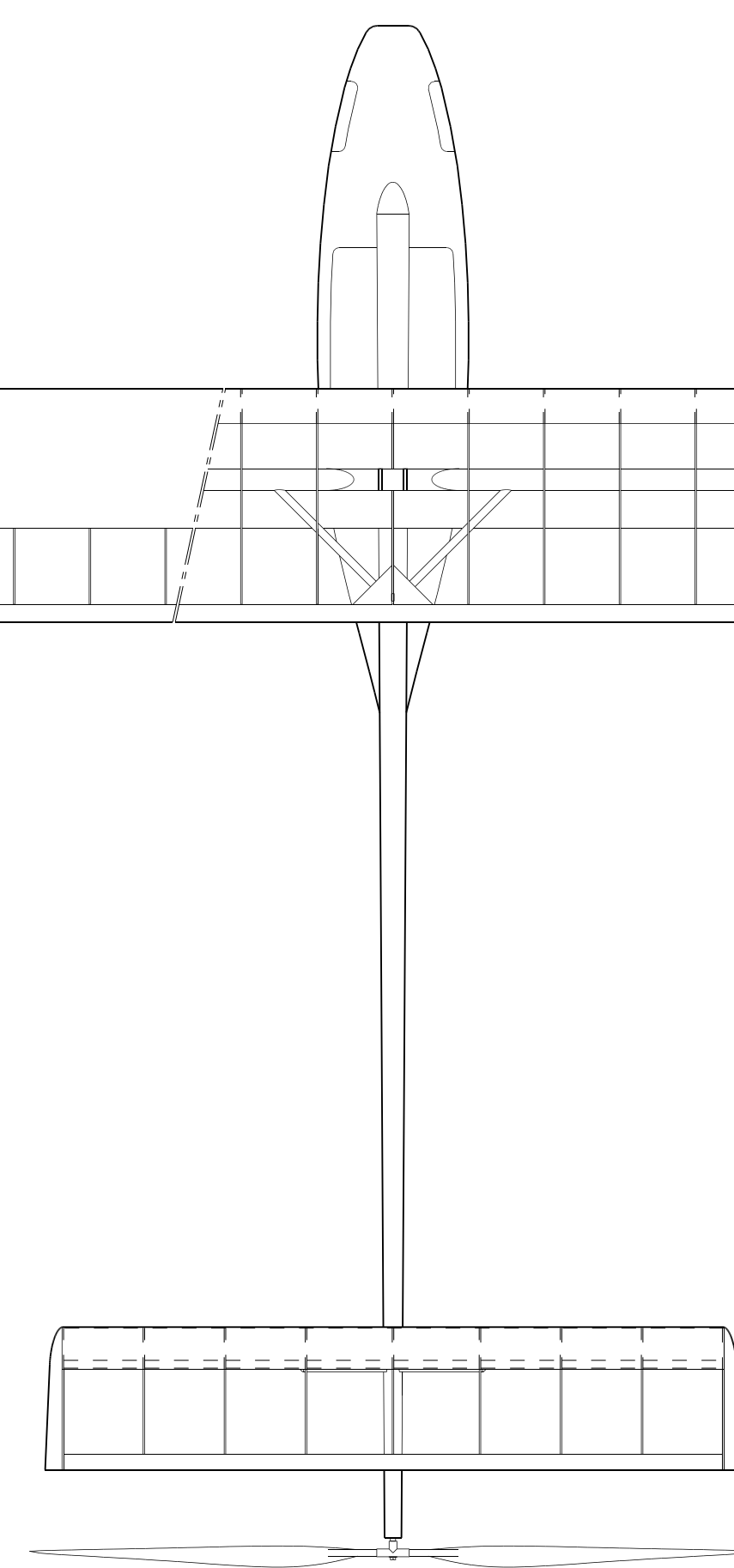
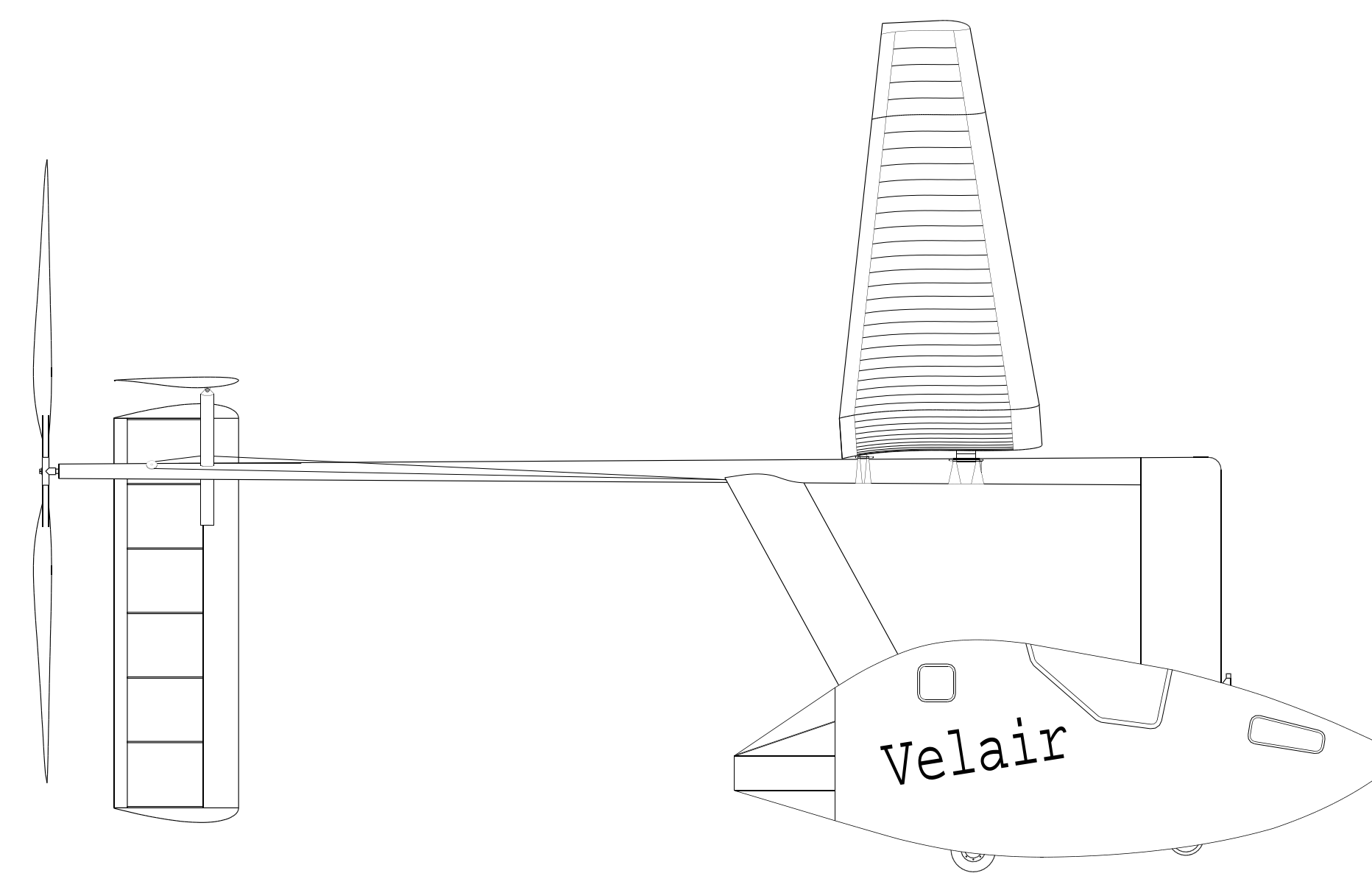
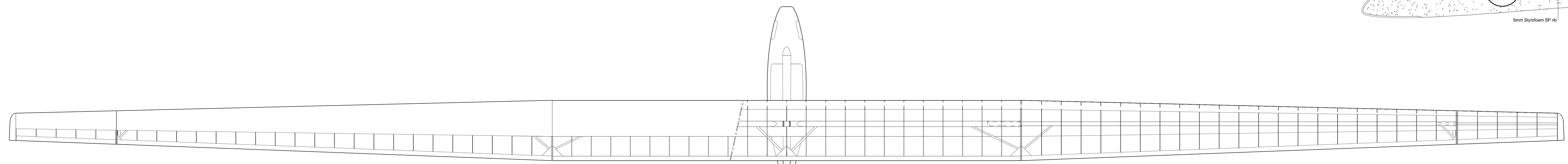
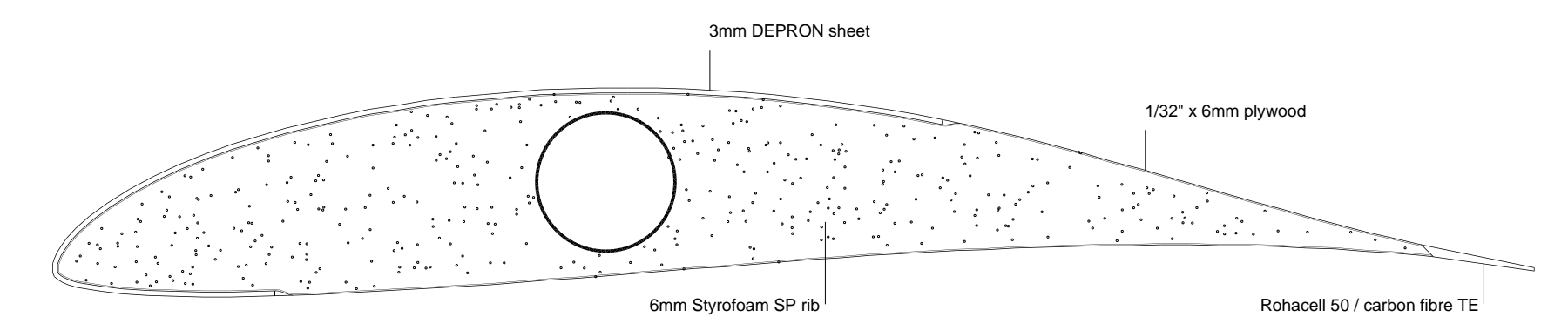

TAIL STRUTS (scale 1:5)

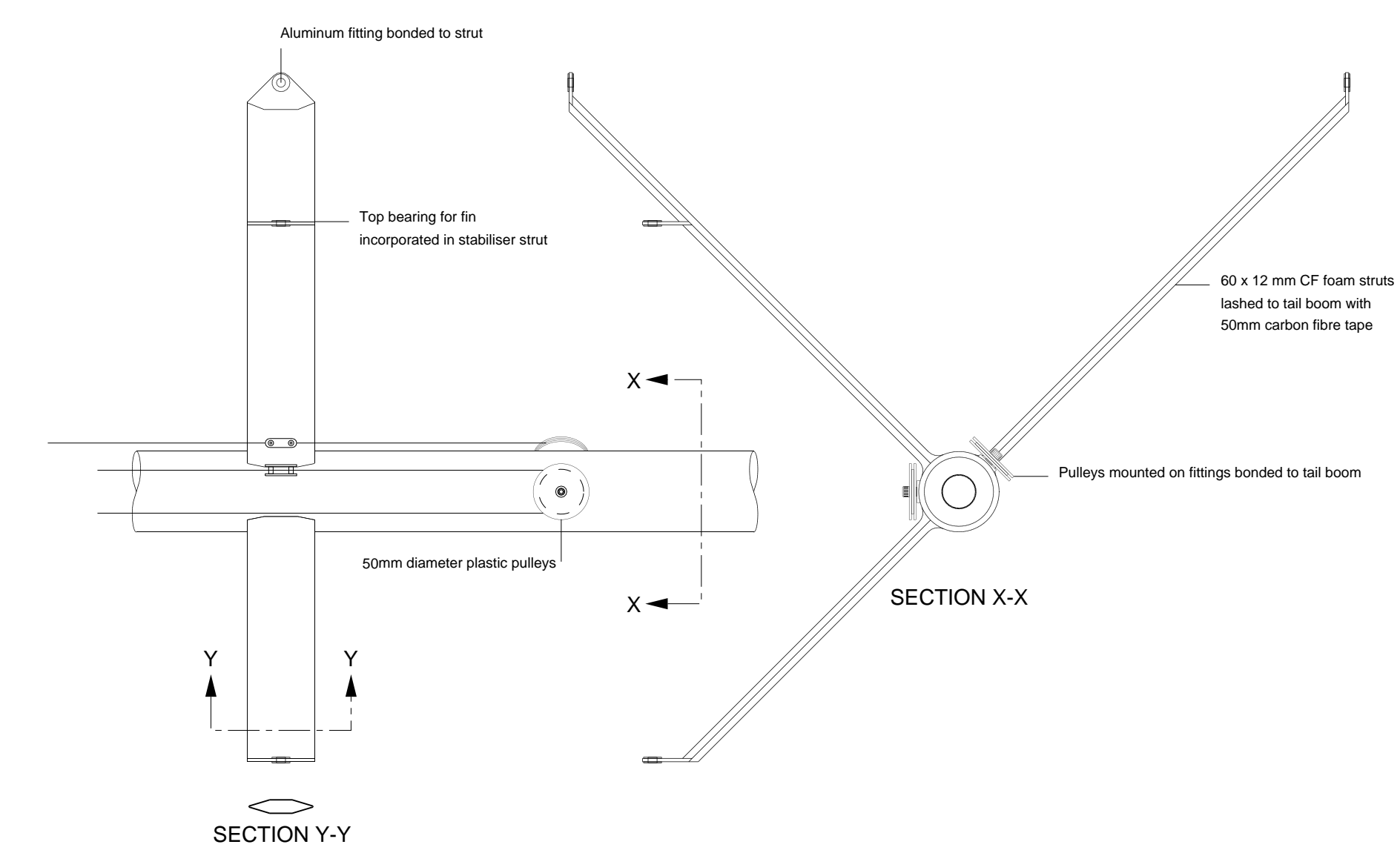

Tail Boom Construction

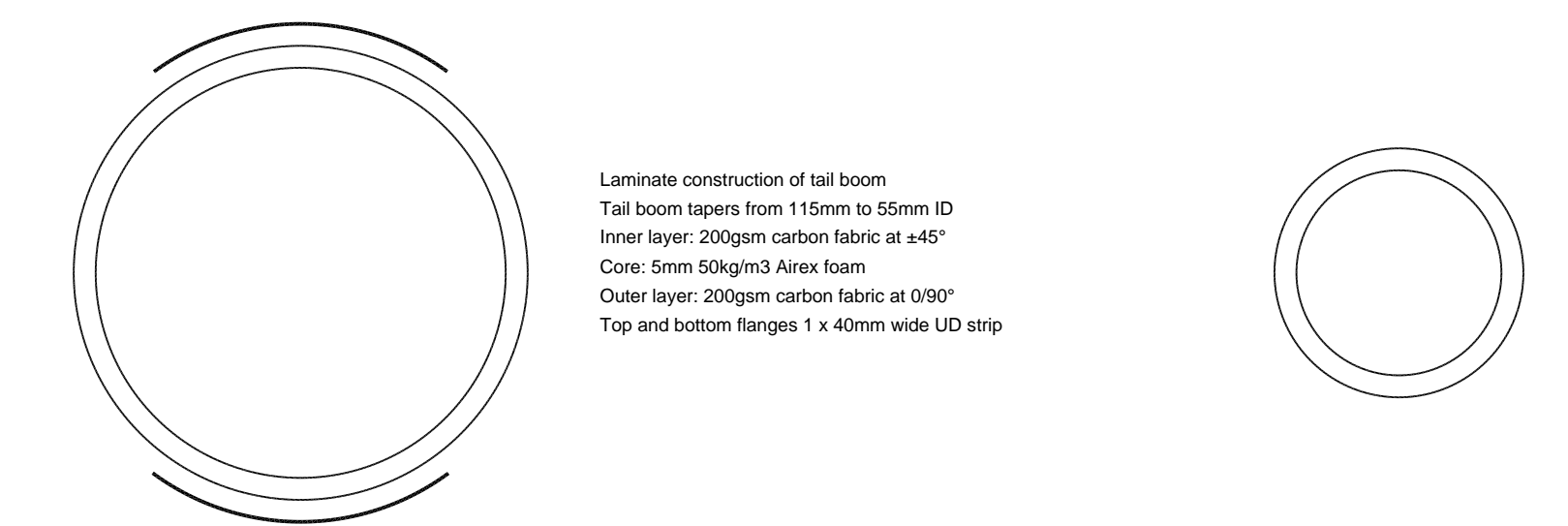

Wing Panel Joints

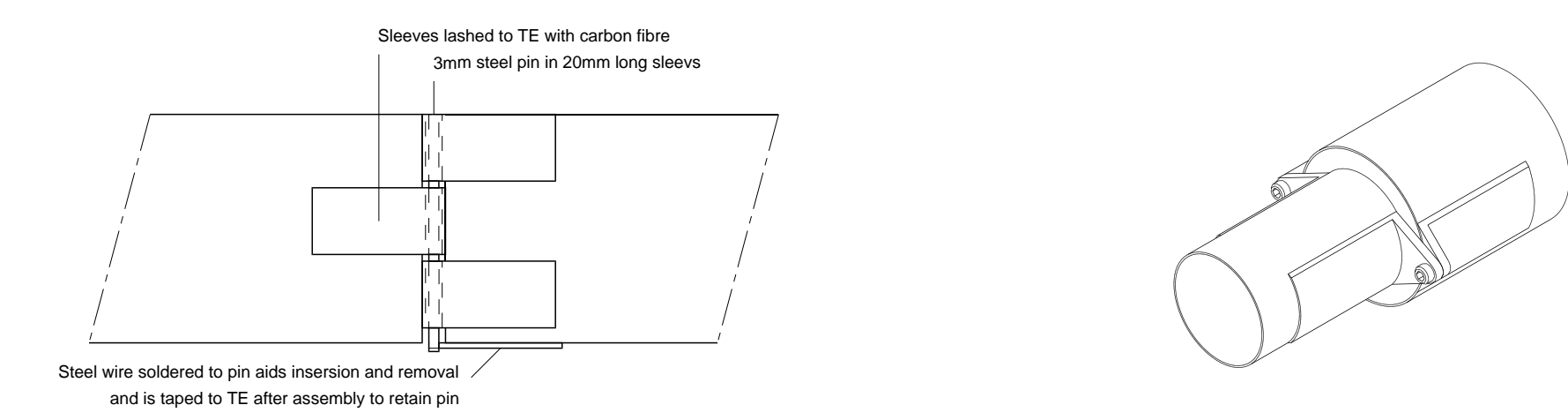
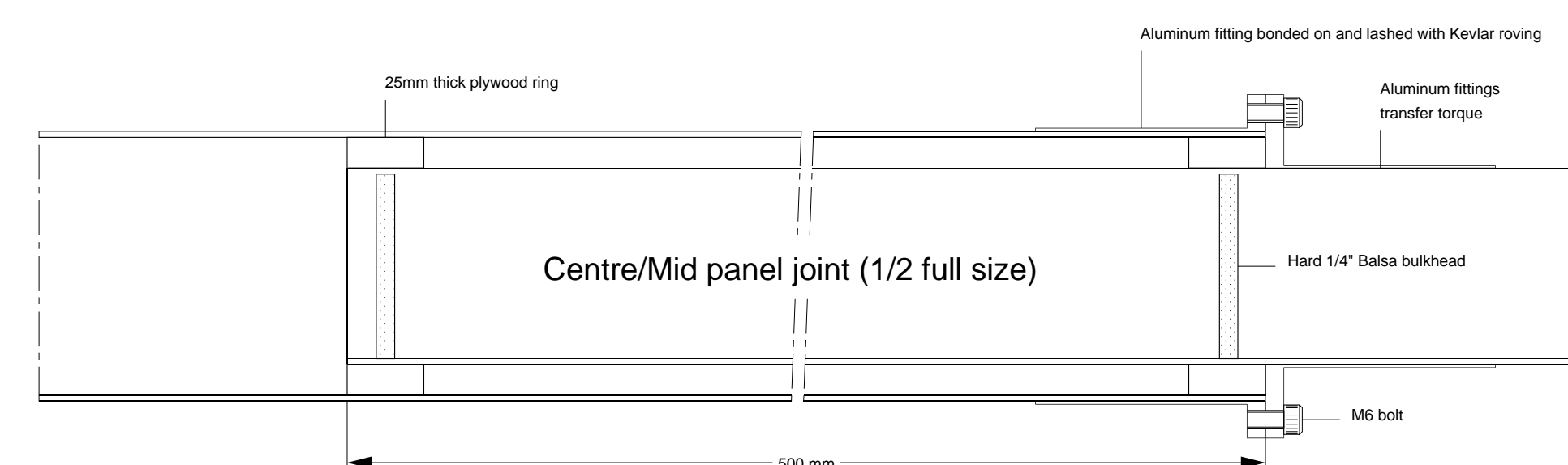

Sketch of Aluminum torque transfer fittings

Wing Spar Laminate

Laminate construction of inboard wing spar at CL
 CIBA-GEIGY T800M10 unidirectional carbon fibre pre prep
 0.125mm cured ply thickness
 8 layers carbon at 45° on a 60mm diameter mandrel
 17 60mm wide layers of carbon at 0°

Laminate construction of inboard wing spar 2.1m from CL
 6 layers carbon at 45°
 11 60mm wide layers of carbon at 0°

Laminate construction of outboard wing spar
 4 layers carbon at 45° on a 60mm diameter mandrel
 9 32.48mm wide layers of carbon at 0°

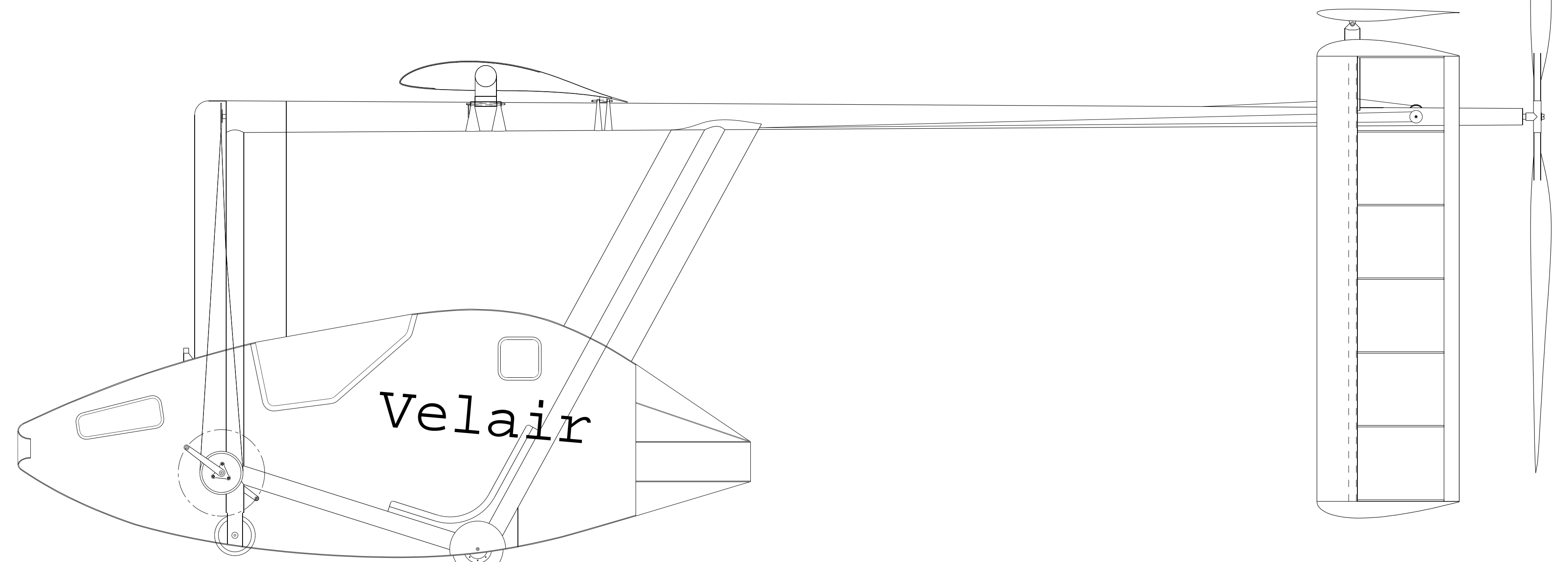
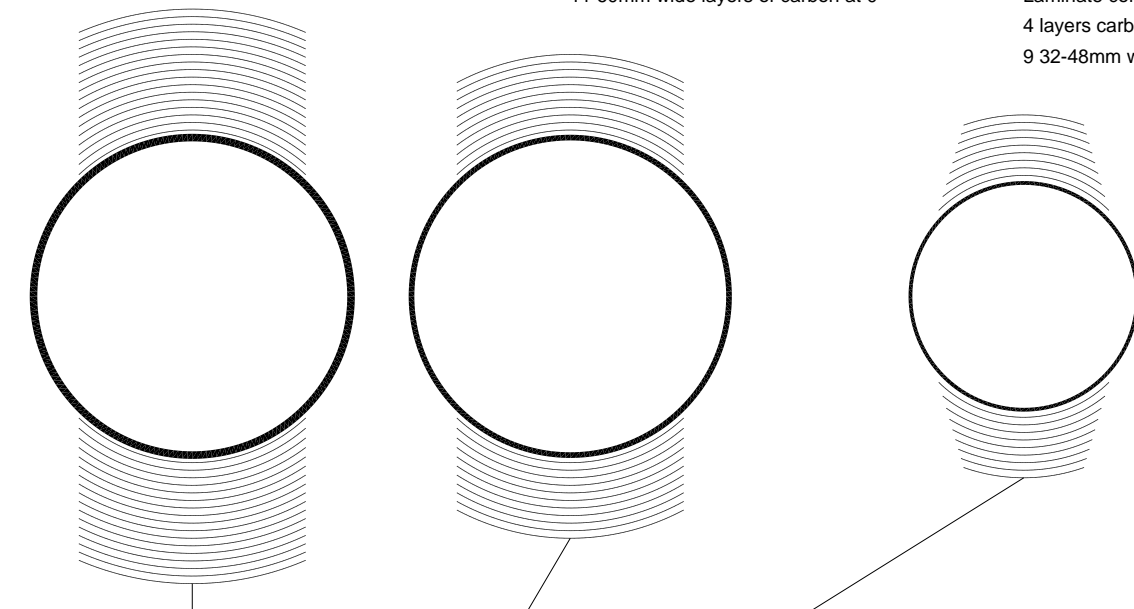

Side view showing internal structure. Scale: 1:12.5

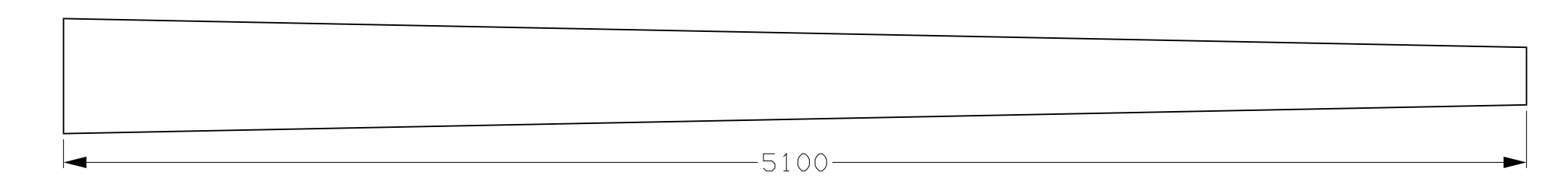

Drive Shaft

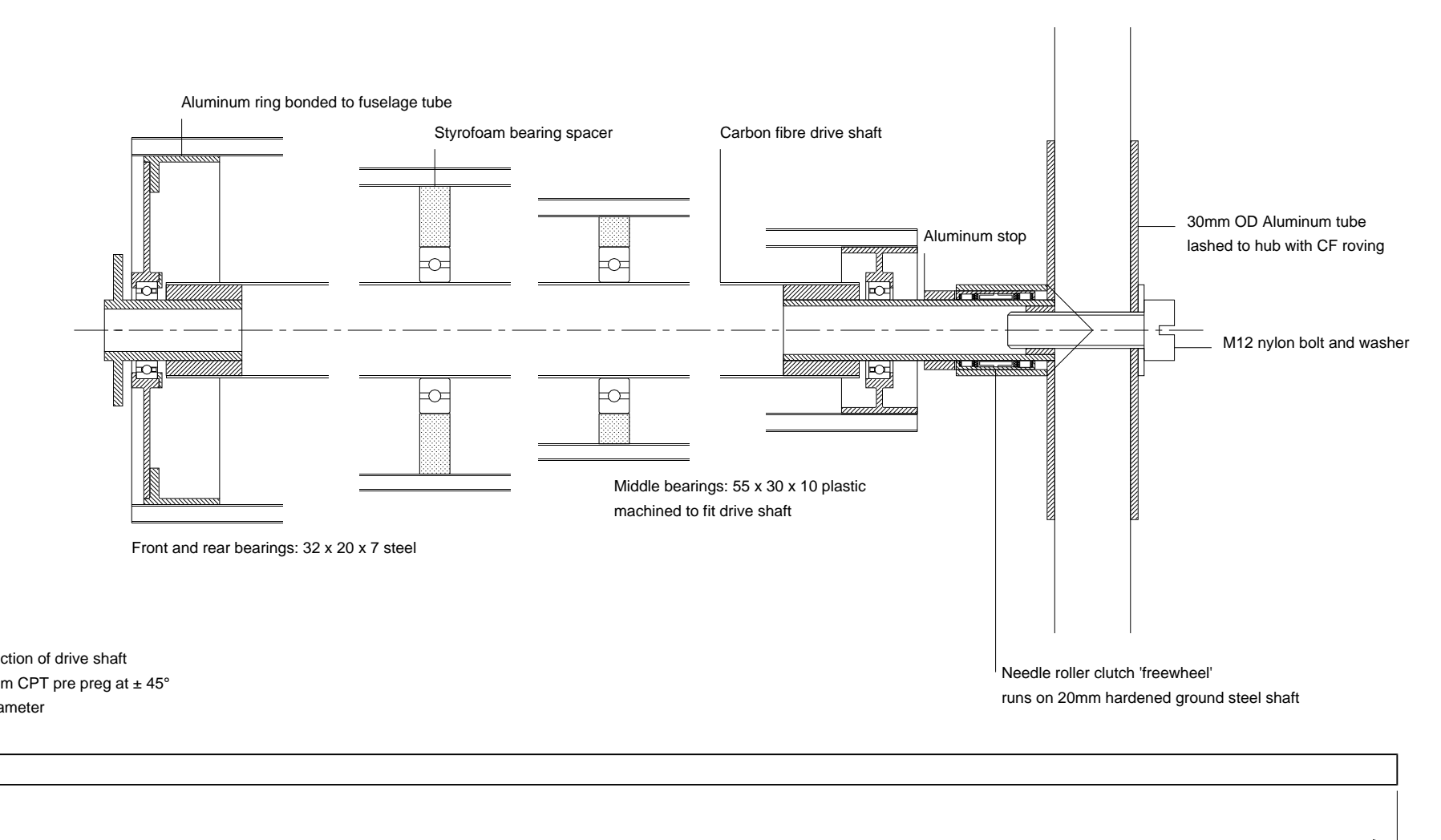

Laminate construction of drive shaft
 6 layers of 0.14mm CFT pre prep at ± 45°
 30mm internal diameter

VELAIR 89 Human Powered Aircraft

Scale in m - 1:25

