

102 ft. span tip

Aircraft skin: .0005" Mylar

transport breaks

All-moving tip aileron

balsa tip structure

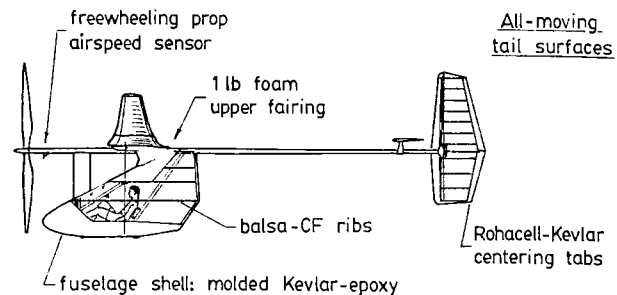
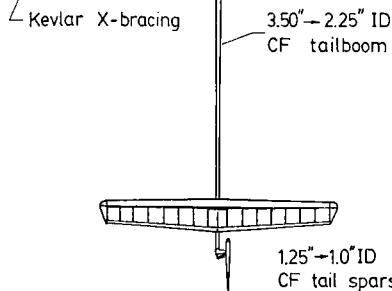
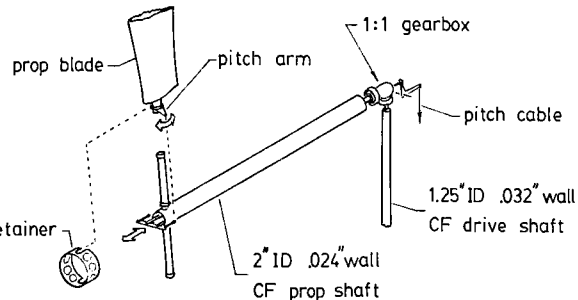

All-moving tail surfaces

11 ft. dia. prop.  
115 rpm at design pitch

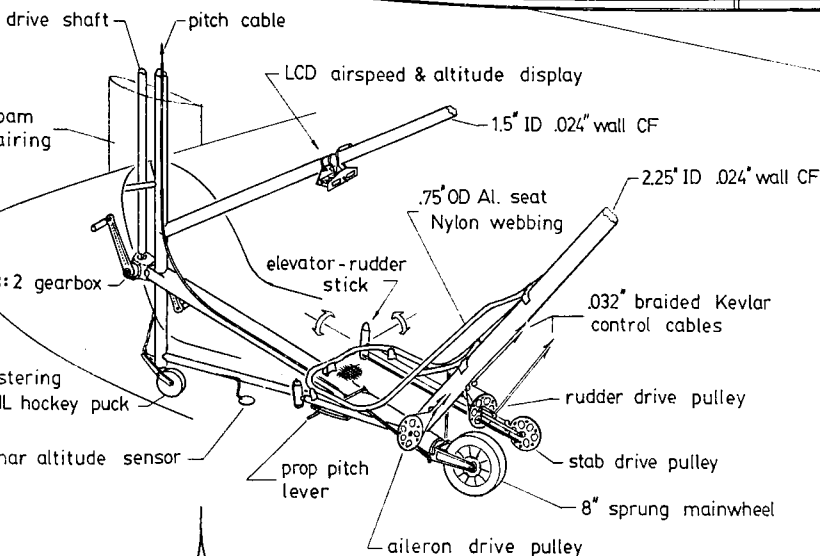

**FAI WORLD RECORD**  
 Closed course distance  
 36.4 miles 2 hr. 14 min.

Empty weight 92 lb.  
Gross weight 242 lb.  
Span 114 ft.  
Wing area 330 sq.ft.  
Cruise speed 14-18 mph  
Pilot power ~0.30 hp

.015" Lexan windshield

.071" steel lift wire

Ventilation  
Ducting

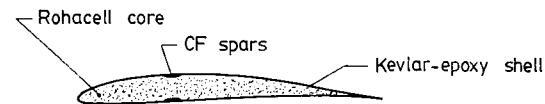

PROP SECTION: DAI 0735

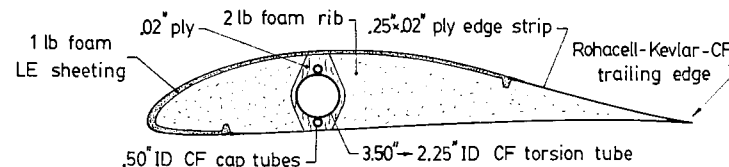

WING CENTER SECTION: DAI 1335